

Filter Resistors

12 / 17.5 / 24 / 36 / 52 / 72.5 kV

IP00–IP23

For indoor and outdoor use



BACKER
FACSA

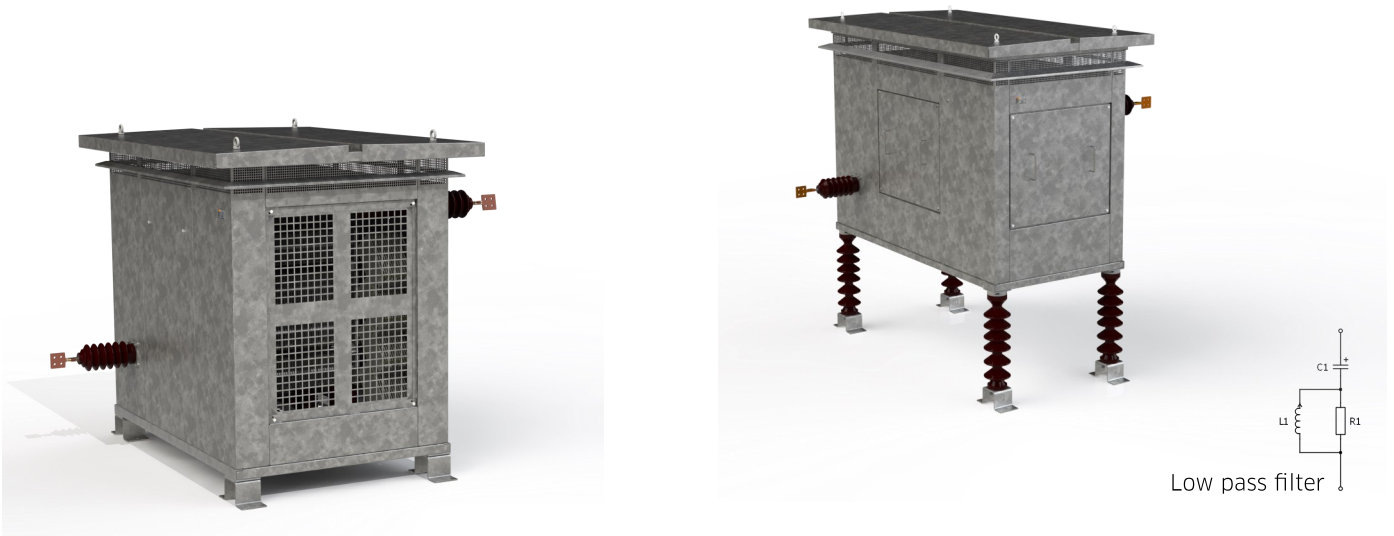

Application

Harmonic Filter Resistors are used to attenuate harmonic frequencies that would otherwise perturb the power grid. In any application where power semiconductor switches are used, such as in High Voltage Direct Current (HVDC) networks, variable-frequency drives or controlled rectifiers, harmonic voltages and currents are generated causing additional losses and interference with other electrical circuits. Harmonic Filter Resistors are used in combination with capacitors and inductors. The filter passes the fundamental frequency through and dissipated the harmonic currents into heat. The power dissipation depends on the sum of all attenuated harmonics.

Filters are build up from inductors, capacitors and resistors. In principle a filter can be build using a capacitor and an inductor. Such a filter will pass the voltage with the basic frequency the filter is designed for while blocking all other frequencies. A disadvantage is that this filter is very sensitive for small changes in the capacitance and inductance values (due to manufacturing, aging and or temperature influences). This can be improved by adding a resistor to the filter. Filters can be divided into different types. For power grid system the most common used are the low pas filter (LRC) and the RC filter. The resistor in the filter is referred to as filter resistor or damping resistor.

A filter resistor must have a stable ohmic value, independent from temperature. By using special alloys as active resistor material this is achieved. The parasitic inductance should be as low as possible for proper filtering.

Typical applications for Harmonic Filter Resistors include HVDC networks, electric arc furnaces, coupling of different distribution networks to avoid synchronization difficulties, elimination of higher frequencies.

Design and auxiliary components

Filter resistors are available for 12 / 17.5 / 24 / 36 / 52 and 72.5kV grid system voltages. In many cases the filter resistor dissipates continuously the power it is rated for. Special design with higher clearance and creepage distances or applications at high altitudes where voltage levels need to be considered, are very well possible.

Enclosures: protection class and materials

The standard enclosure is designed to IP23 according IEC60529 (to prevent the ingress of foreign bodies greater than 12mm, and rain falling at any angle up to 60° from the vertical). This rating is suitable for indoor and outdoor use as it allows sufficient cooling and provides more than adequate protection unless the environmental conditions are extreme.

Standard enclosures are manufactured from unpainted galvanized steel DX51D+Z275-M-A-E. Enclosures in stainless steel or mild steel painted in any specific color are on request. If required, other enclosure materials and special finishes can be arranged to comply with users specifications.

Main parameters

- Ohmic value at rated current and or cold state
- Total (harmonic) power dissipated in the filter resistor
- If applicable, short time current capability
- Insulation voltage level
- Clearance and creepage distances

Additional parameters

- Maximum inductance
- Connection / terminal layout
- Mounting: stacked or side-by-side
- Environment



1FRC

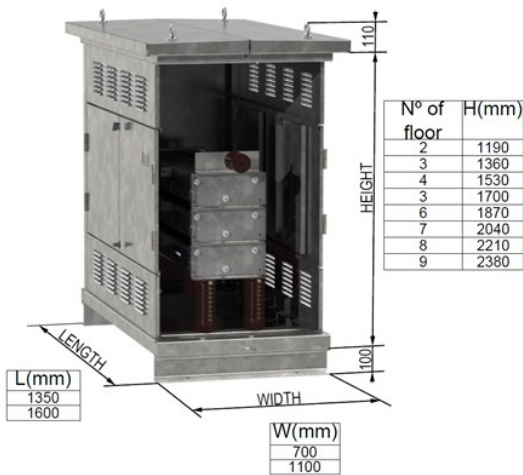

2FRC

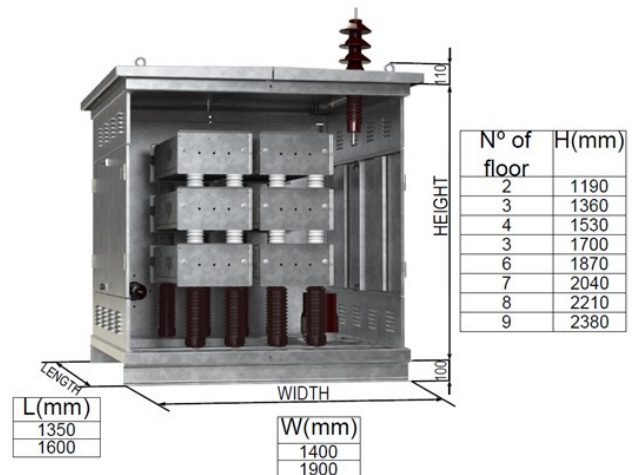

3FRC

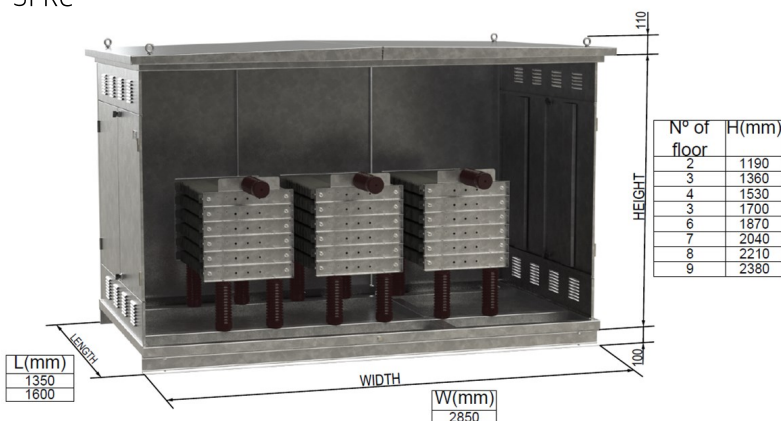

Routine and type tests

⇒ Routine tests are performed on all units manufactured:

- Measurement of insulation resistance between enclosure and resistor
- Dielectric test 50Hz/1 minute between active part en housing (voltage levels up to 120kV) conform directive IEC 60298: 1990
- Measurement of inductance value
- Measurement of DC resistance
- Measurement of metal surface thickness (galvanized DX51D+Z275-M-A-E or painted)
- Dimensional check according relevant drawings

⇒ Type tests (on demand):

- Temperature rise test
- Impulse voltage test (1.2 / 50 μ s)
- AC resistance test
- Ingress Protection test
- Seismic test



Standards / directives

- Many electricity companies force directives for users on their distribution network. For each area/country and or electricity company different standards apply like CEI, CENELEC and IEEE.
 - CIGRÉ WG 14.30 Section 17 Resistors (specification and design for AC filter in HVDC applications)
 - IEC 60071-1 (insulation coordination)
 - IEC 60529 (Ingress Protection degree)

All manufacture takes place in our factory operating to ISO 9001 quality standard.

A Factory Acceptance Test (FAT) is very common to conduct and arrangements for such test can be made. Most tests are conducted in house. Very special tests can be performed at (nearby) test facilities.

Depending on the energy that the resistor has to withstand without exceeding the maximum ohmic value permitted at steady state and the insulation required different dimensions on the enclosure are selected as given in underneath table:

GENERAL DATA			
Dimension reference	1FRC	2FRC	3FRC
Insulation voltage level (kV)	12 / 1.5 / 24 / 36 / 52 / 72.5		
Length (mm)	1350 / 1600		
Width (mm)	700 / 1100	1400 / 1900	2850
Height (mm) / No. Floors	1190 / 1360 / 1530 / 1700 / 1870 / 2040 / 2210 / 2380		
Standards reference	EDF HN 64-S-50		
	IEC 60071-1		
	IEC 60529		
Cooling method.	Self cooling		
De-rating at altitude	According IEE Std 32		
Resistor tolerance	± 10 % as standard, other on request		
Resistor active part materials	AISI-304 / AISI-310 / Cr-Al / AISI-430		
Enclosure materials	Galvanized steel as standard, other on request		
Connections	Cable, bushings		

Backer–Facsca S.L.

Filter resistors damp higher frequency voltages and currents to improve the quality of the electrical grid. Filter resistors are offered for 12, 17.5, 24, 36, 52 and 72.5kV systems. Backer–Facsca engineers and produces filter resistors that comply with various national and international standards. All filter resistors are submitted to a routine test and, if required, a type test.

The design of the resistor depends on the nominal power, the voltage level, the type and place of electrical connection and environmental conditions. Standard material for the housing is unpainted galvanized steel DX51D+Z275-M-A-E, however, special coatings and or other materials can be used on request.

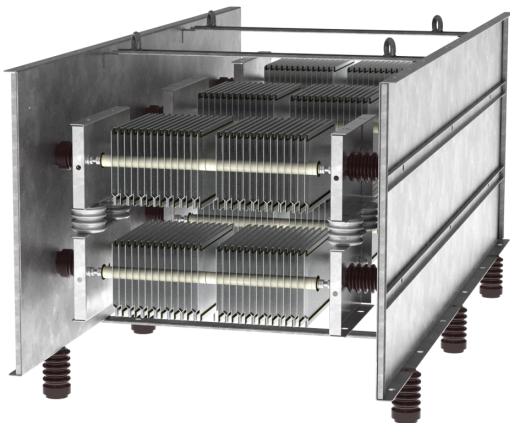

IP00 resistor: 3 x 7R
3 x 18kW
Insulation Level: 12 kV.

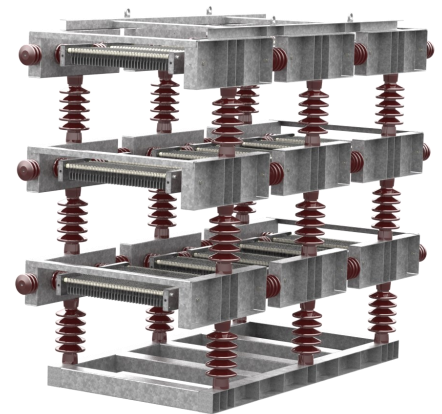

IP00 resistor: 3 x 38R
3 x 67kW
Insulation Level: 36 kV.

